



Progress of Chubu Electric Power Group Medium-term Management Plan

April 28, 2023

Chubu Electric Power Co., Inc.

Progress of Chubu Electric Power Group Medium-term Management Plan

Item	Page
Introduction	3
Toward Providing Value Demanded by Stakeholders	4
Management Vision 2.0 and Medium-term Management Plan	5
Chubu Electric Power Group Medium-term Management Targets (April 2022 setting)	6
I Review of the First Year (FY2022) of Medium-term Management Plan	7
Financial Performance	8
Results and Issues for FY2022	9
II Initiatives for Attaining Medium-term Management Targets	10
Priority Items	11
Provide Safe, Affordable and Stable Energy	12
Toward the Building of a Next-generation Power Network	13
Sophisticate and Enhance Efficiency of Networks by Introducing Next-generation Technologies	14
Initiatives for Realizing a Decarbonized Society	15~17
Accelerate Initiatives for Global Business	18
Contribute to Solving Local Issues and Revitalizing Local Communities	19
Providing New Value to Customers and Society	20
Further Improve Efficiency in Accordance with the Characteristics of Each Business Area	21
Raising the Value of Human Capital	22
Promoting Technology R&D and Intellectual Property Activities	23
Initiatives for Compliance	24

Introduction

In its Medium-term Management Plan announced in 2022, the Chubu Electric Power Group **established Medium-term Management Targets** for FY 2025 (**consolidated ordinary income of 180 billion yen or more and ROIC of 3.0% or more***) as the midpoint up to Management Vision 2.0.

Looking back, we faced **extremely harsh conditions** during first fiscal year of these targets (FY2022). These included **expectations of temporarily operating in the red as Chubu Electric Power Miraiz and Chubu Electric Power Grid** suffered a significant worsening of income and expenditures during the year **due to increased power procurement costs** accompanying soaring resource prices. Despite these headwinds, we **ultimately recorded consolidated ordinary income of approximately 156 billion yen thanks to a subsequent sharp downturn in resource prices** that mirrored the impact of a record-breaking warm winter in Europe and **to Groupwide efforts to expand thoroughgoing measures for enhancing management efficiency and to strengthen market responsiveness.**

Our **business environment that includes resource prices is expected remain uncertain.** Nevertheless, we are keenly aware of **its unwavering mission of providing high-quality energy that considers the global environment encompassing decarbonization in a safer, more affordable and more stable manner** across the entire value chain, from fuel procurement to the delivery of electricity to customers, and the Group will work in unison to fulfill this mission under any circumstances.

Alongside these measures, we will **accelerate its global business** while working toward **creating new value by providing services that enrich the lives of its customers and contribute to solving local issues and revitalizing communities.** Through these initiatives, we **aims to attain its management targets and realize Management Vision 2.0.**

I believe that realizing all of these initiatives is contingent on winning the trust of our customers and society. With this in mind, we **sincerely apologizes** for any concerns it caused due to such incidents as **the leakage of information obtained through its wheeling business** as well as an **investigation by the Japan Fair Trade Commission for a suspected violation of the Antimonopoly Act concerning the supply** of extra-high voltage and high voltage power in the Chubu region. **Mindful that the trust of our customers and society forms the bedrock of our business operations, the management team that includes me will take the lead and make its utmost efforts to once again deepen our awareness of compliance.**

Going forward, **we will contribute to the development of a sustainable society together with our customers, shareholders, community residents, business partners and other stakeholders** by undertaking business activities in accordance with the Chubu Electric Power Group CSR Declaration, which serves as the Group's Code of Conduct.



April 2023
President and Director
Chubu Electric Power Co., Inc.

Hayashi Kingo

Toward Providing Value Demanded by Stakeholders

- Chubu Electric Power Group, as a **corporate group that continues to achieve growth with customers and society**, is committed to **contributing to the development of a sustainable society** by demonstrating total strengths in our businesses centered on energy while leveraging individualities of our group companies, giving top priority to safety and striving to both provide a stable supply of energy and protect the global environment.

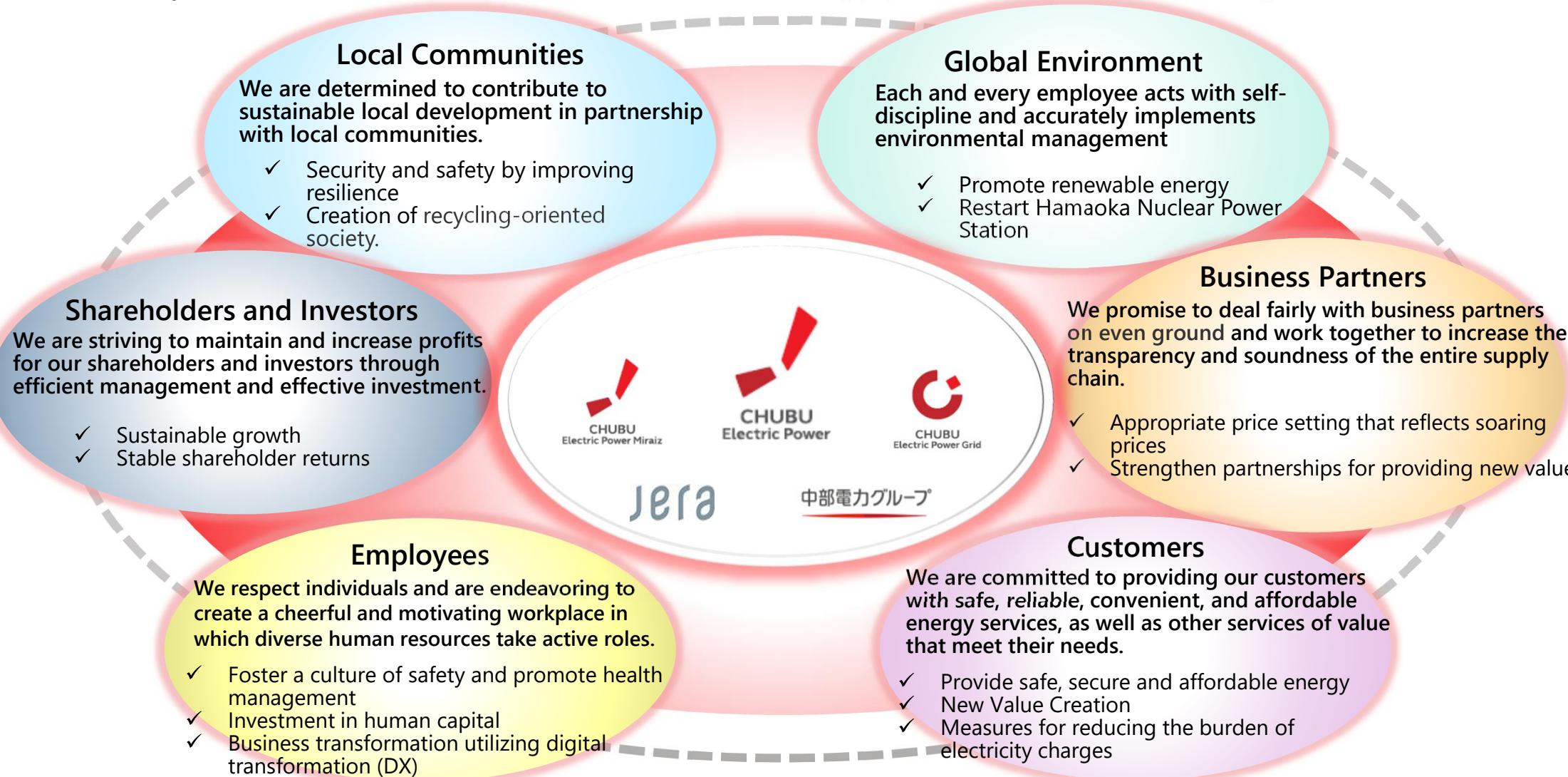

Management Vision 2.0 and Medium-term Management Plan

- Chubu Electric Power Group companies express initiatives starting with solving local and social issues to **achieve sustainable growth together with all stakeholders.**



Click here
for details. 

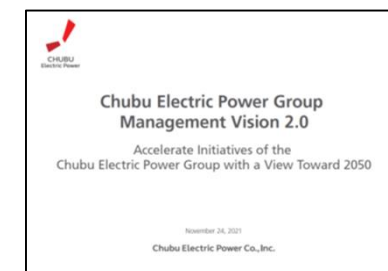

- Chubu Electric Power has specifically expressed its **Medium-term Management Targets** as a midpoint toward **the realization of Management Vision 2.0** and as well as its initiatives for attaining these targets.



Click here
for details. 



Chubu Electric Power Group Medium-term Management Targets (April 2022 setting)

Chubu Electric Power Group Medium-term Management Targets

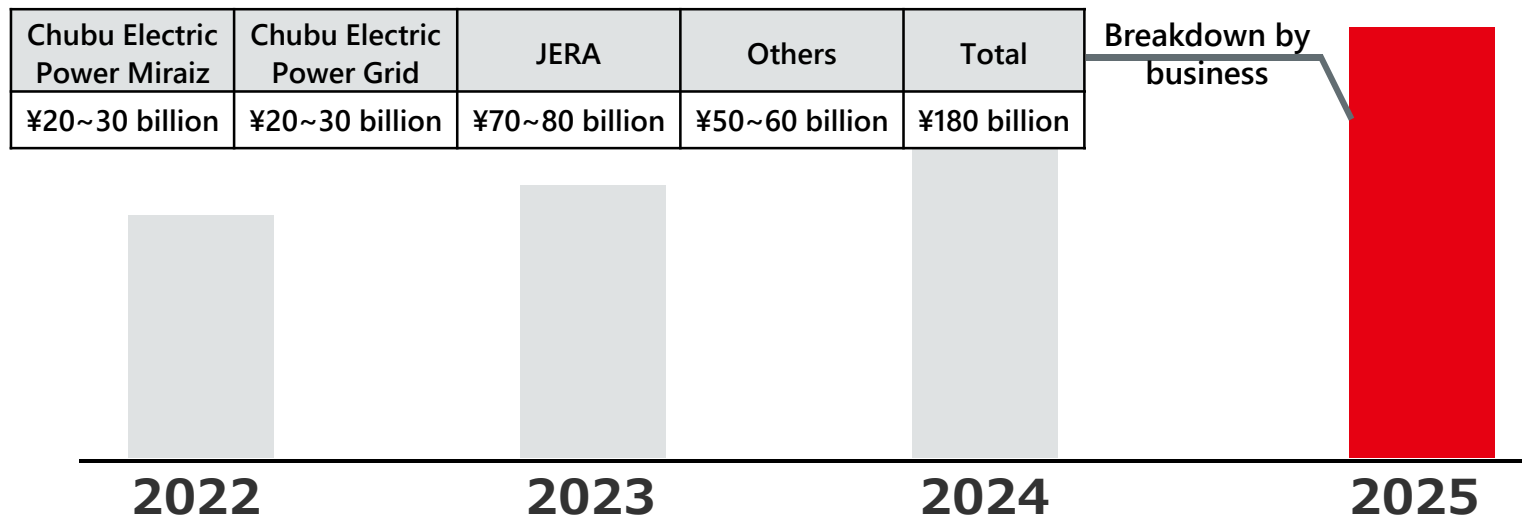

FY2025
Consolidated Ordinary Income*
¥180 billion or more
ROIC*
3.0% or more

* Excluding the time-lag impact

Financial Indicators Serving as Rough Targets

Item		FY2025
Growth potential	Cash Flows from Operating Activities(CFFO)	Approx. 900 billion yen (cumulative from FY2022 to FY 2025)
	Strategic investment amount	Approx. 450 billion yen (cumulative from FY 2022 to FY 2025)
Efficiency	ROE*	Approx. 7.0%
Stability	Shareholders' equity ratio	Maintain 30% or more

Approach to Investment and Capital Policy

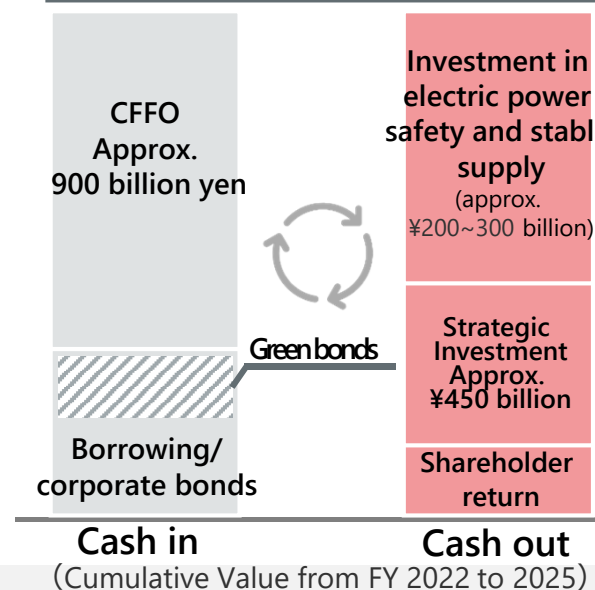

Approach to Shareholder return

We will continue to pursue **stable dividends**, as well as consider our profit growth. Our target **consolidated payout ratio is over 30%**

I Review of the First Year (FY2022) of Medium-term Management Plan

Financial Performance

- In FY 2022 consolidated ordinary income amounted to **156 billion yen**. Despite expected ongoing uncertainty in the business environment that includes resource prices, Chubu Electric Power will continually aim to achieve its management targets.

(billion yen)

Consolidated Ordinary Income and ROIC (excluding the time-lag impact)

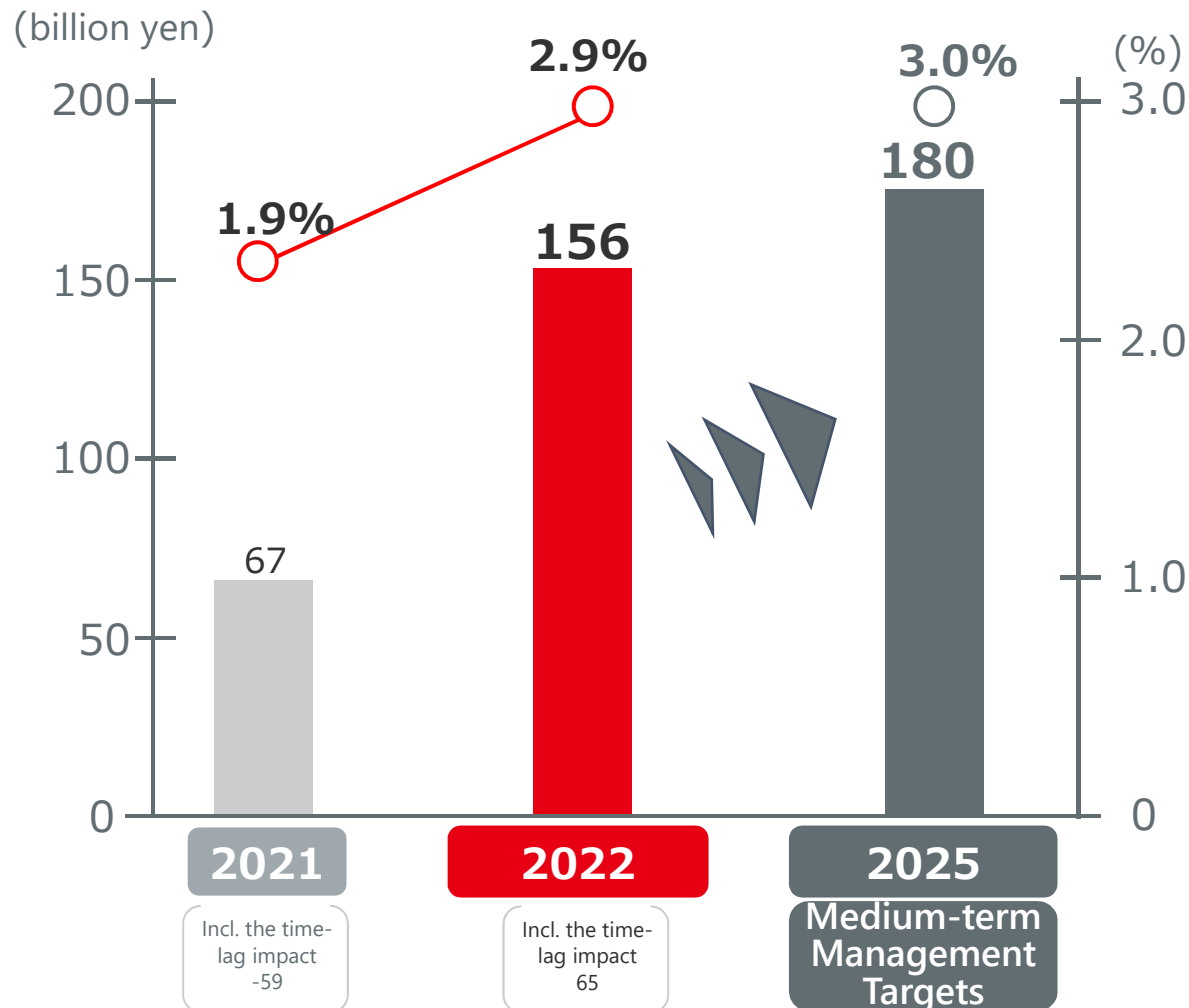

Sector	FY2022 Results	FY2025 Medium-term Management Targets
Chubu Electric Power Miraiz	64.8	20~30
Chubu Electric Power Grid	7.0	20~30
JERA	67.0	70~80
Others	17.5	50~60
Total	156	180

Impact of soaring resource price

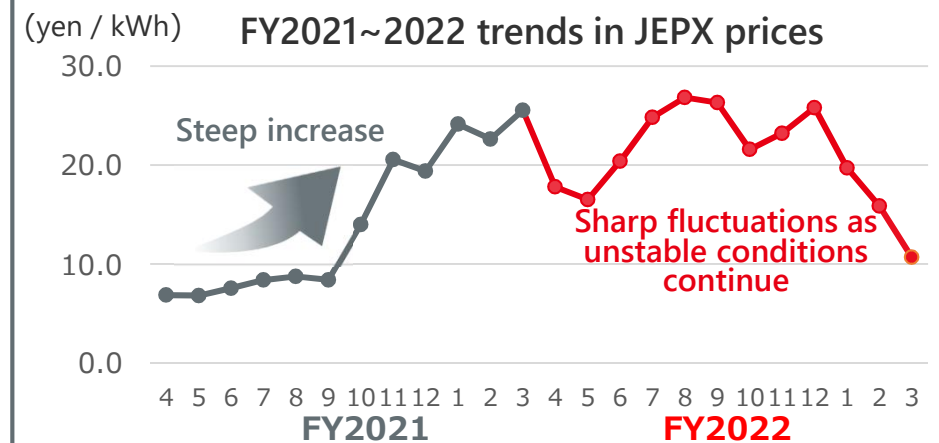

I Review of the First year (FY2022) of Medium-term Management Plan

Results and Issues for FY2022

Area	Results and Issues	Direction of Responses
<p>Energy Business Area</p>	<p>Results</p> <ul style="list-style-type: none"> Even though we operated amid an unstable business environment that includes resource prices, we implemented flexible responses utilizing the features of our model that splits off power generation and sales while securing stable supplies. Implemented initiatives to reduce power procurement costs and carried out sales activities based on procurement costs at Chubu Electric Power Miraiz Implemented a fuel trading business that response the high volatility of resource prices at JERAGM. <hr/> <p>Issues</p> <ul style="list-style-type: none"> Correction of business structure with high risk of income and expenditure fluctuations due to resource price shifts Achieve balance between sustainable initiatives toward CN*2 and the strengthening of resilience 	<ul style="list-style-type: none"> Provide safe, affordable and stable energy Build next-generation power networks Accelerate initiatives for realizing a decarbonized society
<p>New Growth Area</p>	<p>Results</p> <ul style="list-style-type: none"> Expand growth areas such as renewable energy power generation, retail sales, and new services in Europe centered on Eneco Cooperation agreement with bp plc for decarbonization in Japan and the Asian region Earn profits through ES-CON JAPAN's autonomous and flexible business operations <hr/> <p>Issues</p> <ul style="list-style-type: none"> Expand service lineup to meet customer needs Promote M&A/quick earning of profits through strategic investment, etc. 	<ul style="list-style-type: none"> Accelerate initiatives for global business Contribute to solving local issues and revitalizing local communities Provide new value to customers and communities
<p>Management Foundation</p>	<p>Results</p> <ul style="list-style-type: none"> Expand mid-career recruitment and strengthen field-specific education in response to business expansion and changes Further enhance management efficiency of the entire Group Establish a joint research course with the aim of establishing lithium-recovery technologies. <hr/> <p>Issues</p> <ul style="list-style-type: none"> Occurrence of incidents such as leakage of information obtained through wheeling business and suspected violations of the Antimonopoly Act by the Japan Fair Trade Commission 	<ul style="list-style-type: none"> Further improve efficiency in accordance with the characteristics of each business area Improve the value of human capital Promoting technology R&D Initiatives for compliance

II Initiatives for Attaining Medium-term Management Targets

Priority Items

We will concentrate its efforts on implementing the following initiatives for attaining the Medium-term Management Targets

Energy Business Area

Provide safe, affordable and stable energy

Build a next-generation power network

Accelerate initiatives for realizing a decarbonized society

New Growth Area

Accelerate initiatives for global business

Contribute to solving local issues and revitalizing local communities

Provide new value to customers and society

Management Foundation

Further improve efficiency in accordance with the characteristics of each business area

Improve the value of human capital

Promote technology R&D and intellectual property activities

Initiatives for compliance

Photo courtesy:
Akita Offshore Wind Corporation

Provide Safe, Affordable and Stable Energy

- **The unstable business environment continues** amid rising uncertainty in the energy market resulting from **extreme volatility of resource prices and exchange rate fluctuations.**
- **Even within such a drastically evolving business environment, the Group will work in unison to provide safe, affordable, and stable energy.**

Stabilize fuel procurement and undertake trading

- **Optimal fuel procurement** that is combined with long-term contracts
- **Earn profits through trading** that response the high volatility of resource prices



Sophistication of risk management

- Initiatives for **risk quantification**
- **Clarify response policies** for **quick responses when risk arises**
- **Examine hedging methods** encompassing swaps and options trading

Effectively utilize demand response

- **Further discovery of demand response resources** owned by customers
- Deployment of **NACHARGE (energy saving program)**

NACHARGE

- **The concept of “use in accordance with amount of renewable energy generated” is incorporated** into conventional “power saving” initiatives.
- **NACHARGE is a service that realizes a decarbonized society through these actions.**



Optimization of procurement portfolio

- **Reduce market procurement ratio** (increase bilateral contract ratio)

Build a next-generation power network

- **Increase and strengthen facilities and sophisticate operations** for large-scale introduction of renewable energy
- **Improve resilience by promoting utilization of distributed energy resources (DER)**

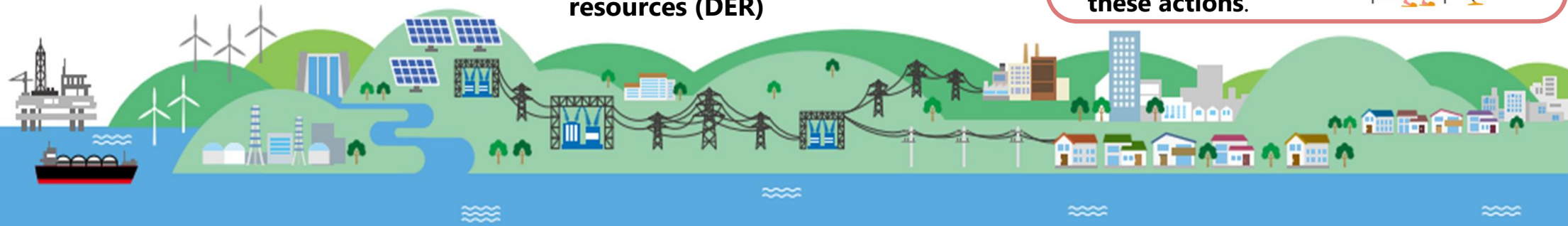

Toward the Building of a Next-generation Power Network

- From FY 2023, a new wheeling charge system was started. Chubu Electric Power Grid is working to build a next-generation network from the perspectives of **decarbonization**; **improving resilience**; **widening of areas**; and **DX, enhancing efficiency, and improving service**.
- We will work to realize low-cost wheeling charges by **improving productivity such as through data utilization** by promoting the realization of **a next-generation network via such measures as sophisticating and digitizing** power transmission and distribution facilities.

Decarbonization

- ✓ **Effectively use existing systems**
Introduce N-1 generation control, non-firm connection, and dynamic line rating (DLR)
- ✓ **Sophisticate power distribution operations**
Introduce voltage adjustment systems and next-generation smart meters

Improve resilience

- ✓ **Responses to frequent occurrence of natural disasters**
Deploy mobile substations, etc.
- ✓ **Promote local production and consumption of electricity**
- ✓ **Strengthen power grid stabilization in times of disasters**
- ✓ **Strengthen cyber security**

Widening of areas

- ✓ **Wide-area system operation**
Develop systems needed for wide-area procurement of adjustment capacity

Improve services for DX/ enhance efficiency

- ✓ **Utilize digital technologies**
Utilize drones, sensors and digitize substations
- ✓ **Improve customer service**
Build systems that contribute to utilizing electric power data

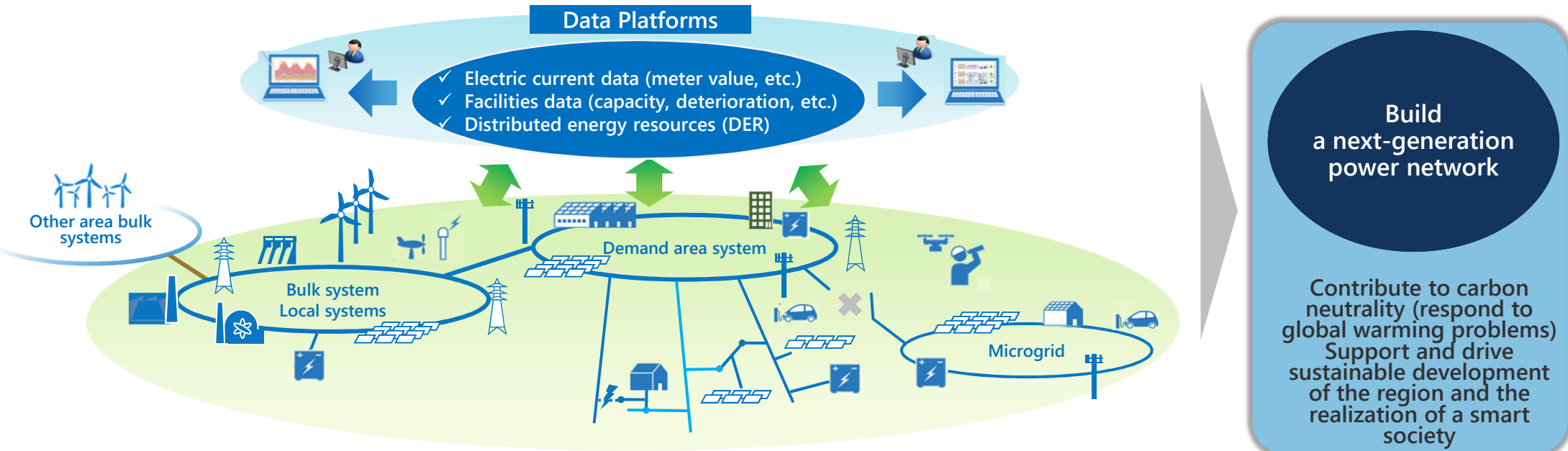

II Initiatives for Attaining Medium-term Management Targets

Sophisticate and Enhance Efficiency of Networks by Introducing Next-generation Technologies

- Chubu Electric Power Grid will **steadily make necessary investments to improve resilience and enhance efficiency** by introducing digitization and other next-generation technologies and **sophisticating its network** as it progresses with the building of a next-generation network.

Decarbonization

Improving resilience

Toward facilities formation that supports carbon neutrality

Development of a new **region-specific demand forecast system (DFES)**

- Highly detailed forecasts of future demand for each distribution line feeder

<p>Smart meter data, etc.</p> <ul style="list-style-type: none"> Demand data PV data EV data Heat pump data 	<p>Macro data</p> <ul style="list-style-type: none"> GDP, IIP forecast Trends in population and number of households PV potential map Vehicle registration data 	<p>Local information</p> <ul style="list-style-type: none"> Large commercial facility installation plan Large PV, storage battery installation plan Large-capacity EV stand installation plan
--	--	---

DFES

(Distribution Future Energy Scenario)

Jointly developed with
Mitsubishi Research Institute

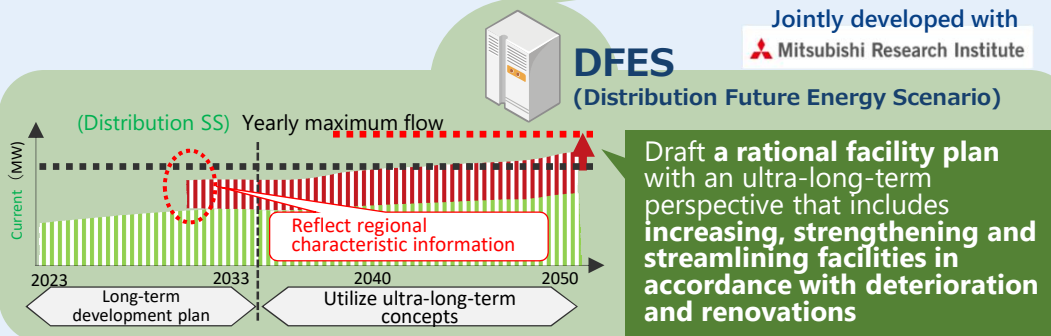

DX/efficiency enhancement

Improving resilience

Realize a next-generation power network (Efficiency-enhancement measures for realizing low wheeling charges)

Select tree felling by using **mobile mapping system (MMS)**

- Extract trees that could contact electric wires with only the use of vehicle operation

DX/efficiency enhancement

Improving resilience

Introduce substation remote monitoring and control systems that apply **IEC61850***

- Utilize general-purpose equipment through the application of international standards
- Reduce costs and improve reliability through control cable reduction

Sophisticate maintenance and operation

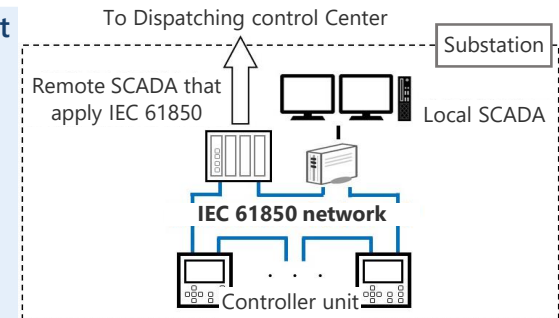

*Communication method based on international standards stipulated by IEC (International Electrotechnical Commission)

Initiatives for Realizing a Decarbonized Society (1/3)

- In working toward realizing a decarbonized society, the Chubu Electric Power Group has formulated **Chubu Electric Power Group Management Vision 2.0, Zero Emissions Challenge 2050 and JERA Zero CO₂ Emissions 2050** and will make efforts to **expand renewable energy** and **pursue zero emission power sources** including **establishment of hydrogen and ammonia supply chains**.

Reference: CO₂ emissions from sales of electrical power
FY2021 results: 41.58 million t-CO₂

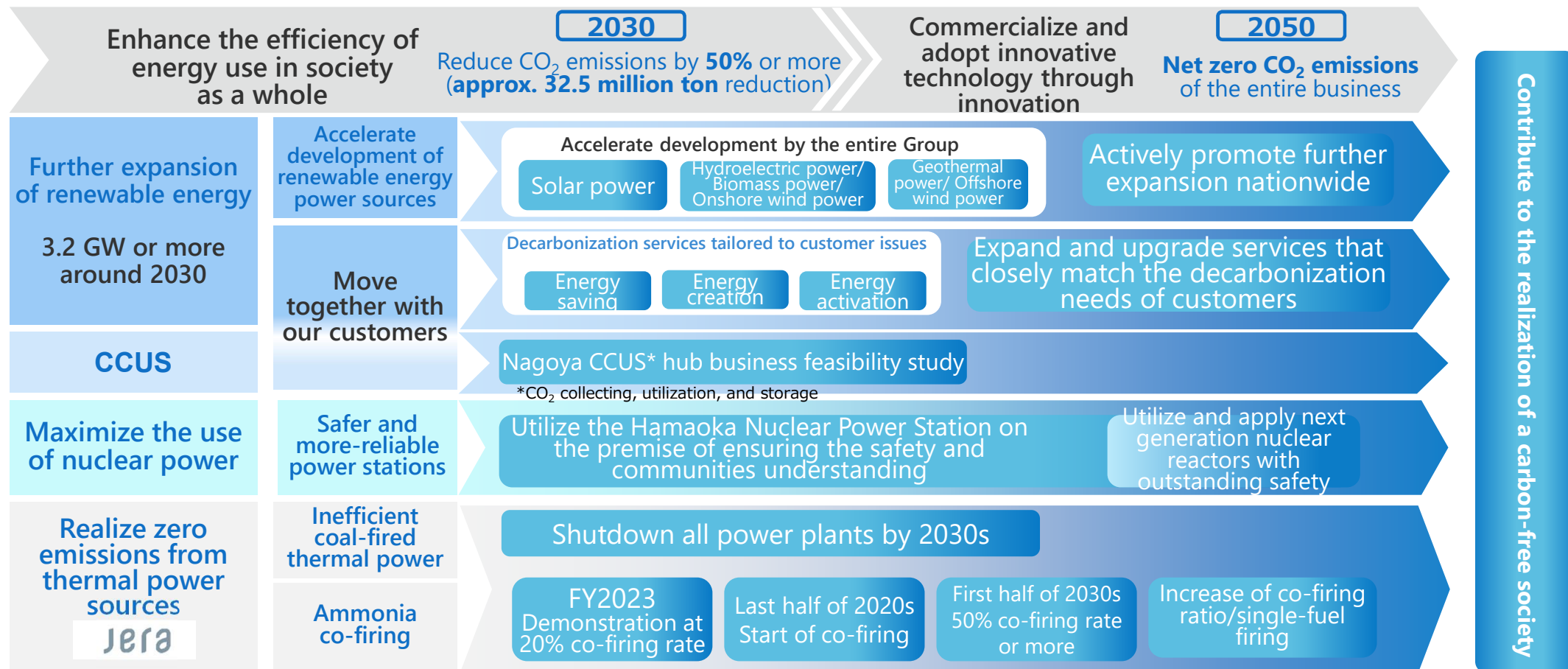

CO₂ reduced by key measures (million t-CO₂/year)

Use of Hamaoka Nuclear Power Plant

When reactivating Units 3, 4 and 5
Approx. **8-9** million t

Reexamining procurement of inefficient coal-fired thermal power sources

When substituting inefficient coal-fired power generation with other power sources
Approx. **4-5** million t

Promote ammonia co-firing for coal-fired power

When co-firing ammonia 20% rate with one or two 1-million kW coal-fired power plants
Approx. **1-2** million t

Initiatives for Realizing a Decarbonized Society (2/3)

Initiatives for expanding renewable energy

- Aim to expand to 3,200 MW or more by around 2030 -

State of progress **740MW (23%)** *1

As of the end of March 2023

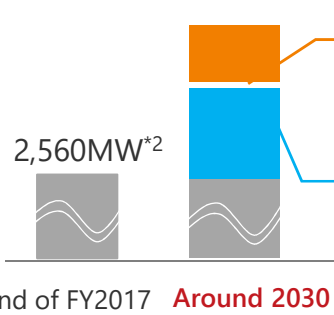

Expand renewable energy together with our customers (1,200 MW or more)

Accelerate development of renewable power sources (2,000 MW or more) by Group companies

*1 Includes projects for which a decision on development has already been made but operations have not started

*2 Capacity includes Group companies.

Main locations starting operations in FY2022

[Click here for details.](#)

Akita Port / Noshiro Port offshore wind power

138,600 kW



Photo courtesy: Akita Offshore Wind Corporation

Chubu Electric Power Group's first geothermal power plant



Okuhida Onsengo Nakao Geothermal

1,998 kW

A new model case based on the coexistence and co-prosperity of hot spring culture and geothermal power generation



Electrification and decarbonization services promoted together with customers that only Chubu Electric Miraiz can provide

Concluded an agreement to implement the first "agriculture-type off-site PPA service" in the Chubu area

Electric power plant operators
Farmers work under the facilities



Long-term procurement from dedicated power sources

Long-term supply from dedicated power sources

Service users



CHUBU Electric Power Miraiz

Three types of support for decarbonization

that only Chubu Electric Miraiz can provide

その手があつたか、脱炭素。



ゼロエミ
チャレンジ
2050

Energy saving

Reduce amount of energy usage

Energy creation

Create the company's own renewable energy

Energy activation

Switch to renewable energy sources

Effects of Introducing Miraiz Green Electricity

地球にやさしく、未来をあかるく。



- ✓ Make your company CO₂-free using electricity with zero CO₂ emissions
- ✓ Support the spread of renewable energy through the payment of electricity charges
- ✓ Toward an intra-regional circular economy through local production for local consumption of renewable energy*
- ✓ PR for your own company's products that utilize renewable energy

* In the case of contract for "CO₂-free electricity (produced within the prefecture).

Initiatives for Realizing a Decarbonized Society (3/3)

Initiatives for restarting the Hamaoka Nuclear Power Station -Aiming for a Safer and Trustworthy Hamaoka Power Station-

- We aim for **the quick restart of operations based on the major premise of assuring safety and obtaining understanding** for the realization of stable power supplies and decarbonization.
- Hamaoka Nuclear Power Station has undergone an inspection by the Nuclear Regulatory Commission to confirm compliance with new regulatory standards, and is currently **making steady progress toward confirmation for standard seismic motion and standard tsunamis. We will respond diligently to enable confirmation of compliance at the earliest possible stage.**

【Responding to inspections checking compliance with new regulatory standards】

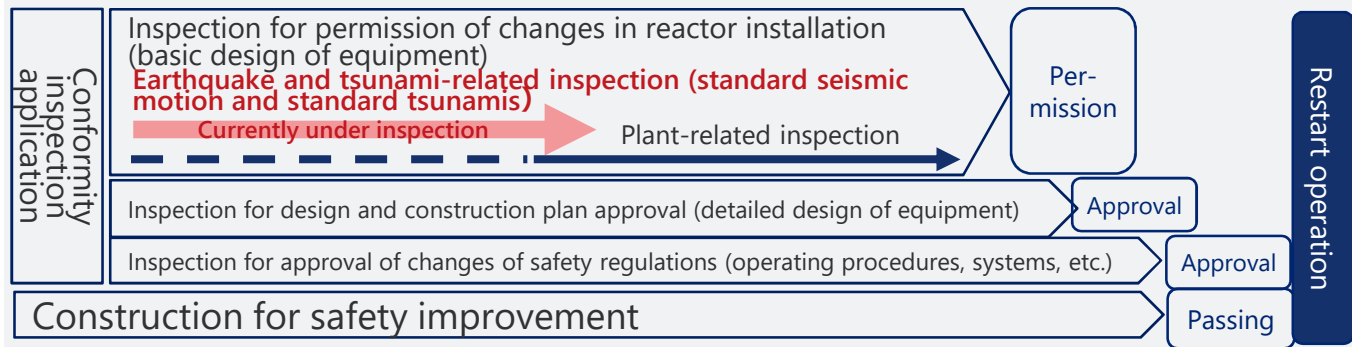

【Dialogue activities with residents of local communities】

By utilizing various opportunities, we explain our efforts made at the Hamaoka Nuclear Power Station. At the same time, we conduct ongoing activities to listen to the voice of local residents and respond earnestly to their concerns, questions, and opinions.



Power station tour

Briefing sessions at local events

Initiatives for realizing zero-emission thermal power generation that does not emit CO₂ Jera

- By promoting **renewable energy and zero emission thermal power** that does not emit CO₂ at the time of power generation by introducing green fuels, JERA will attempt to achieve zero emissions—with zero CO₂ emissions emitted from domestic and overseas businesses—**by 2050.**



Procurement of fuel ammonia

- Work to **build and expand our supply chain**, which includes conducting **international bidding**, for procuring fuel ammonia.

JERA has **begun considering collaboration** with two global ammonia manufacturing companies, **Yara International ASA and CF Industries.**

Accelerate Initiatives for Global Business

Toward becoming a decarbonized energy company, mainly in Europe and Asia

As a Japanese utility company, in our global business we will **contribute to the realization of a decarbonized society, mainly in Europe and Asia**, while working to **further expand earnings**.

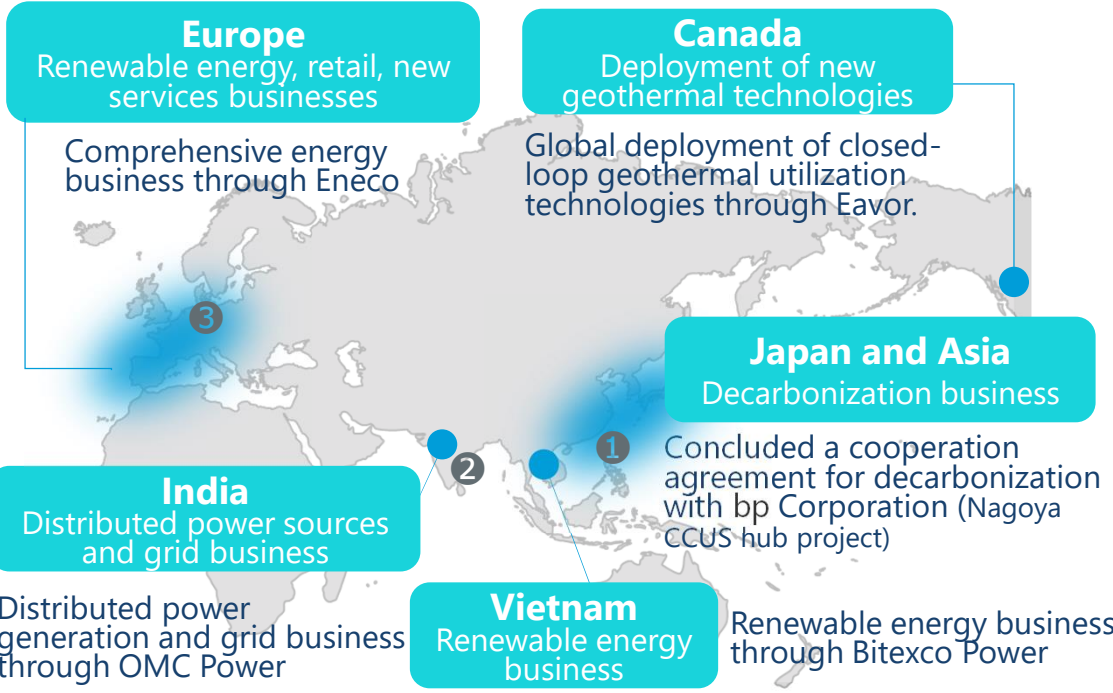

Jera
Major participation projects
JERA will contribute to the healthy growth and development of the world, mainly in Asia, by providing clean energy supply bases that combine renewable energy with low-carbon thermal power.

Formosa ①
IPP offshore wind power station business (Taiwan)

ReNew Power ②
Wind and solar power business (India)

Parkwind ③
IPP offshore wind power station business (Belgium)

Closed-loop geothermal utilization technologies through Eavor

[The Group's first investment in an overseas geothermal-related company]



A Canadian global start-up company undertaking **world-first R&D in closed-loop geothermal utilization technology** with the aim of commercialization.

- Geothermal technology involves circulating water in a closed loop underground to extract heat efficiently.
- Eavor holds numerous patents related to excavation design needed for the operation of this technology.



Cooperation agreement for decarbonization in Japan and the Asian region

[Support decarbonization around Nagoya Port]

In working toward **the realization of CCUS**, we have **begun surveys related to CO₂ collection/aggregation and effective use as well as transport to overseas CO₂ storage sites**.

[Characteristics of Nagoya Port]

- Japan's largest port in terms of cargo handling volume
- Accounts for **3% of total CO₂ emissions in Japan**



Contribute to Solving Local Issues and Revitalizing Local Communities

Community creation driven by the Chubu Electric Power Group

Community development in unison with the region

- **Chuden Real Estate** is proceeding with **community development in Mizuho-ku, Nagoya city and Kasugai city**. (Effective utilization of former company housing site)
- With an eye toward social and regional issues, we will make efforts in areas such as **multi-generational coexistence, environmental coexistence, social contributions** and will also contribute to regional development through **community development**.

Mizuho-ku, Nagoya city



Community development that anticipates the needs of the time

- Aim to **contribute to the revitalization of the local community through integrated development of ES CON FIELD HOKKAIDO and the surrounding area**.

Condominium

Senior-citizen residence

Commercial facility

Hotel



Provide new solutions that help resolve regional issues

- We will provide solutions matched to local needs and issues and contribute to building a **decarbonized and recycling-oriented society**.
- In the resource recycling business, we will collaborate with Terrarem Group Co., Ltd. (former Ichikawa Kankyo Holdings) and aim for **quick business development in the Chubu area**.
- We will also promote initiatives in business areas following its resources recycling business.

Regional infrastructure businesses

Resource recycling businesses

Further utilize unused regional resources and environmental value



Local community and customers

Forest management businesses

Effectively utilize forest resources
Conserve forest environment



Water supply and sewerage businesses

Enhance efficiency and sophisticate water supply and sewerage infrastructure operation



Regional transportation businesses

Provide sustainable transportation services in accordance with regional characteristics



Realization of a decarbonized society

Realization of a recycling-oriented society

Solving regional issues

Providing New Value to Customers and Society

Provide community-based healthcare services

- We will contribute to extending healthy life expectancies in local communities and support the development of "healthy communities*" by providing community-based healthcare services that provide consistent support ranging from health promotion (pre-symptomatic diseases) to treatment and coexistence.

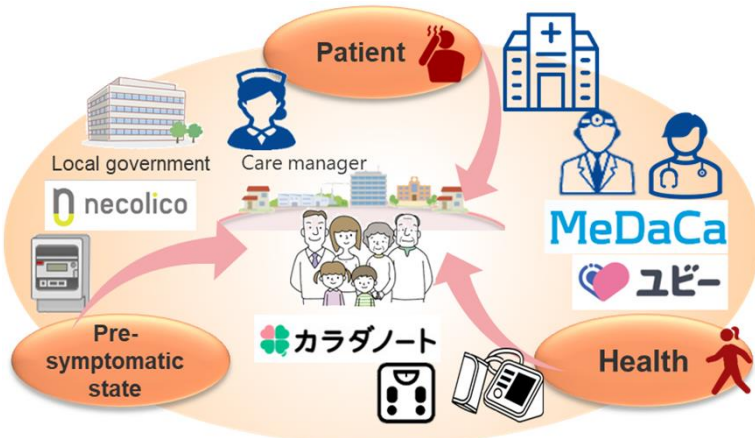

*Besides physical health, this is where every person can live a safe and secure life with a sense of their respective purpose in life and have a genuine sense of happiness

ユビ- : This is a symptom search engine that can search for related disease names and nearby medical institutions by answering questions generated by AI and checking symptoms.

MeDaCa : Provides online medical examination tools and links test results from medical institutions with individuals.

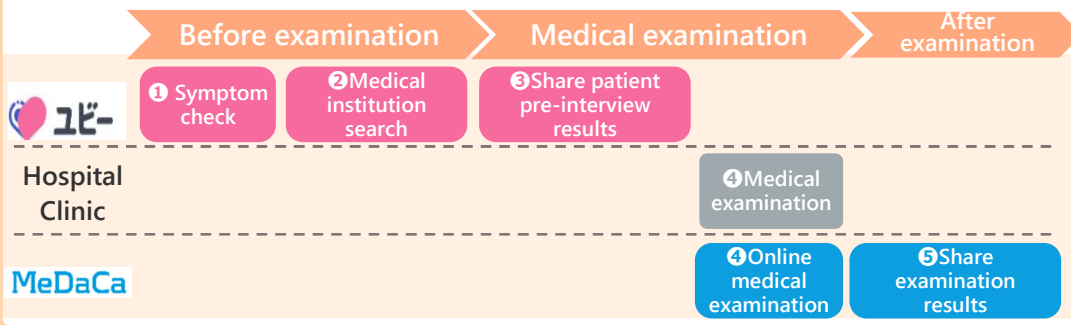

Life Services that nurture family bonds and connections

- Chubu Electric Miraiz Connect will continue to provide a connected and expanding world that will be near your side and serve as source of assistance for the future.



♡ テラシテ

- This service analyzes changes in electricity usage obtained from smart meters installed in elderly people's homes using Miraiz Connect's proprietary algorithm and issues notifications when an abnormality is detected.



- Reassurance in seeing how elderly are living
- No need to install equipment that must be paid for
- Just a monthly fee of 550 yen (tax included)

TSUNAGU table

食卓と地域をつなぐ

- The TSUNAGU table is a food *fukubukuro* (grab bag) packed with items that can no longer be sold at stores for various reasons even though there are no quality problems.
- Not only can this be purchased at a maximum 50% discount, this purchase alone also contributes to reducing food loss and to community promotion.



Further Improve Efficiency in Accordance with the Characteristics of Each Business Area

- We will **promote the autonomous management of each business area while appropriately implementing management that supports each business such as by undertaking optimal resource allocation and monitoring.**
- Furthermore, to achieve **sustainable growth together with our shareholders and investors**, we will work to **gain an understanding and earn acclaim for our policies and initiatives through active dialogue and disclosure with the aim of raising our corporate value.**

Business management using ROIC

With our strategic investments now in a major phase of expansion, we will place increased emphasis on the perspective of efficiency that also encompasses our existing business fields.

Business areas

Promotion of autonomous management

- Establish business targets that are connected to consolidated ROIC targets
- Incorporate business targets into KGIs and KPIs
- Manage portfolio within each business

Generating returns (ROIC) exceeding the cost of capital (WACC)



Management

Establishing management to support business

- Examine business portfolio based on risk/return characteristics of each business
- Optimal allocation of management resources
- Review through monitoring
- Undertake appropriate dialogue with capital markets, reduce fund-procurement costs

Establish business targets, KGIs and KPIs in accordance with the characteristics of each business area. Promote autonomous management to improve efficiency

Energy business area

• Renewable energy business

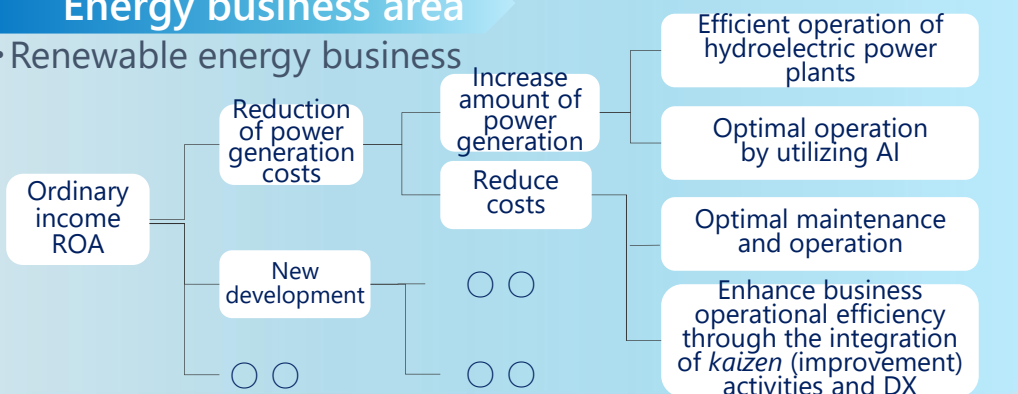

New growth area

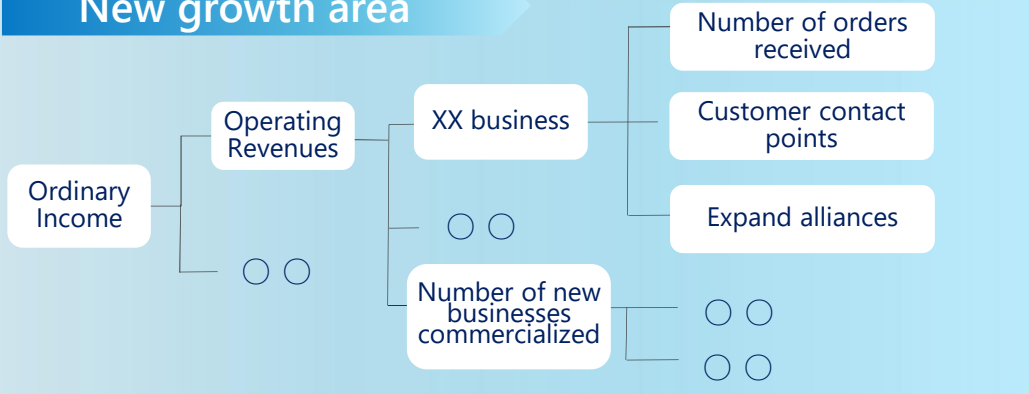

Raising the Value of Human Capital

- In working toward the attainment of the targets set in Management Vision 2.0, we will provide **opportunities and support employees who meet the challenge of self-transformation with the aim of promoting the growth and active roles of each and every one of our human resources, who are the essence of corporate value, as we strive to improve the future value of these human resources.**
- We will also proceed with **the establishment of an environment where human resources can deploy their abilities to the absolute fullest based on the recognition that it is essential to create an environment in which each and every one of our diverse human resources can work safely and in good physical and mental health and lead fulfilling lives.**

Human resources strategy

-Toward raising the future value of human resources-

Establish work environment for safe and healthy work

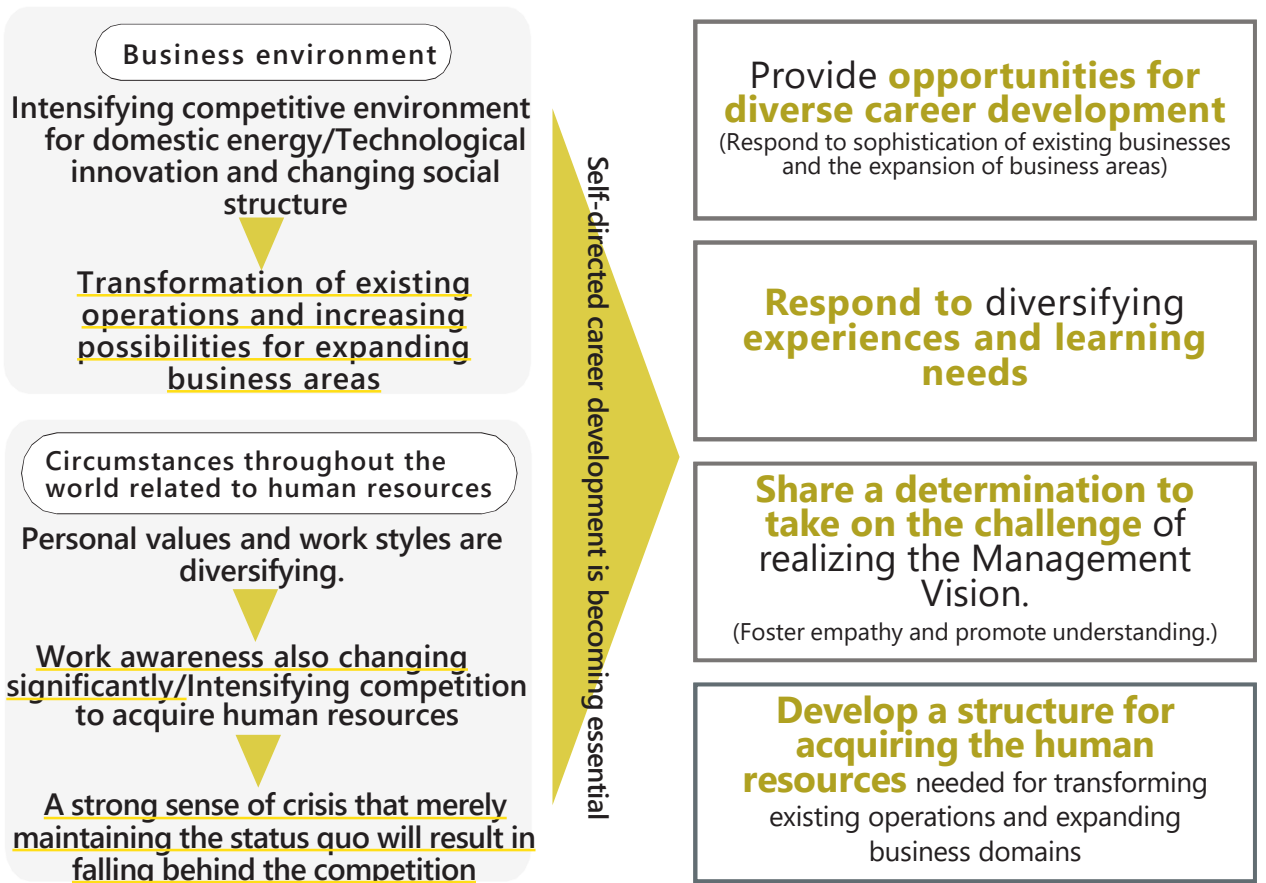

Promoting Technology R&D and Intellectual Property Activities

- In addition to resolving on-site issues, we are promoting technology R & D **centered on decarbonization areas in seven priority fields for technological development** set based on **Management Vision 2.0**.
- The Chubu Electric Power Group will work toward the social implementation of innovative technologies by **combining the engineering and industrial perspectives cultivated to the present by the Group with the academic and social needs perspectives of universities and research institutes**.

Seven priority fields and main initiatives set based on Management Vision 2.0

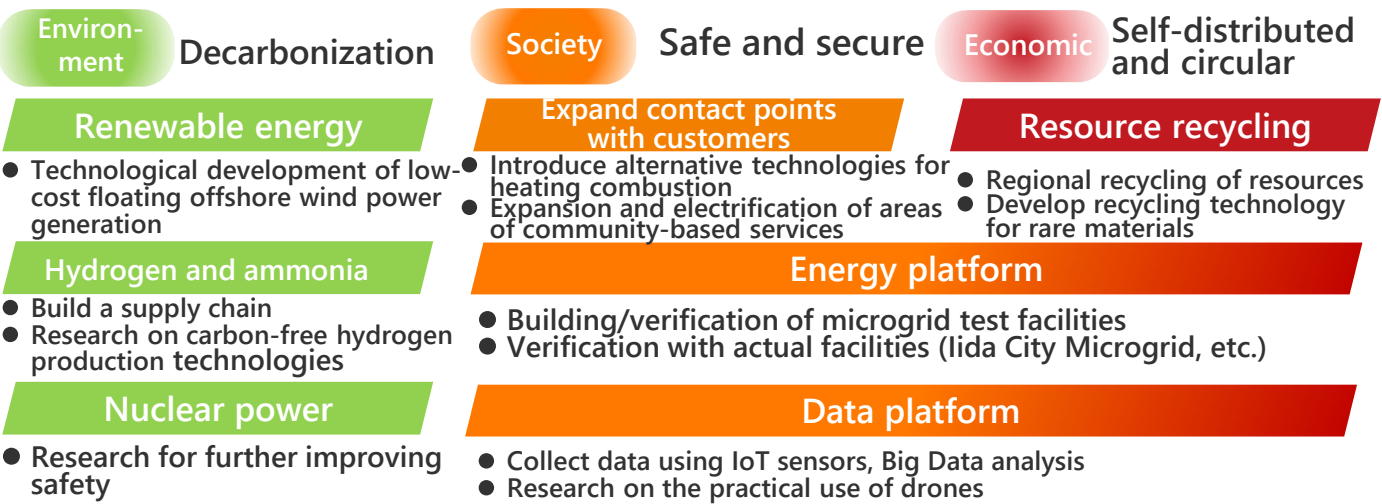

Holding Techno Fairs

We hold Techno Fairs to enable visitors to view a wide range of technology R & D initiatives.

- The Techno Fair marked the milestone of being convened for **the 30th time** and was held at the Research & Development Division, Chubu Electric Power MIRAI TOWER and on the dedicated website.
- **Introduce 61 exhibits** centering on the latest research results in seven priority fields



Initiatives toward social implementation of innovative technologies

- Initiatives toward social implementation of innovative technologies**
- We will take a bird's-eye view of social issues, promote co-creation initiatives (**coordination functions**) in each stage from discovery of seeds to commercialization and industrialization.
- Set up a Chief Standardization Officer (CSO)**
- Chubu Electric Power Group will accelerate initiatives for the widespread social application of its technology development achievements.



Set up a joint-research course with Hirosaki University with the aim of establishing efficient lithium recovery technology. Established a satellite hub within Chubu Electric Power to promote research.

Intellectual property activities

Through technology R&D and business activities, we will create intellectual properties and quickly and reliably acquire rights.

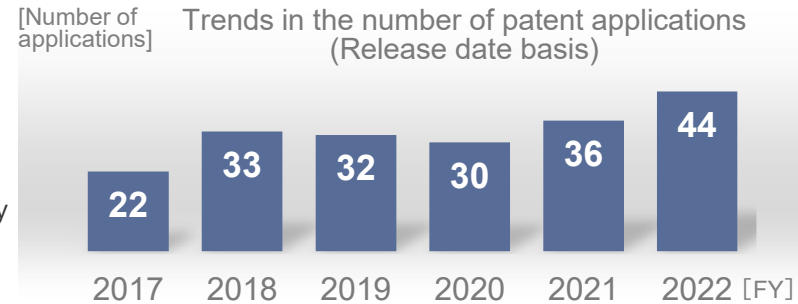

Initiatives for Compliance

- Chubu Electric Power Group will continue undertaking traditional activities such as **promoting autonomy and mutual enlightenment and firmly entrench a mechanism for legal compliance** and will strive to **further ensure thorough compliance and improve governance**.
- At this time we are seriously reflecting on **our inappropriate handling of information obtained in the wheeling business, the suspicion of our violation of the Antimonopoly Act, and the occurrence of inappropriate events** and are thus working to **strengthen various types of initiatives**.

Various types of initiatives

<p>Promote autonomy and mutual enlightenment</p>	<p>Firmly entrench a structure for legal compliance</p>	<p>Group-wide unified compliance promotion (deployment of support measures for Group companies)</p>
<ul style="list-style-type: none"> • Formulate and implement action plans at each workplace (legal compliance, harassment, etc.) • Improve compliance risk literacy including seminars and management staff training 	<ul style="list-style-type: none"> • Appropriately operate and firmly entrench various rules such as contact rules and Guidelines for Giving and Receiving Money and Goods. • Education for understanding and promoting contact rules 	<p>CCO Liaison Committee</p> <ul style="list-style-type: none"> • Exchange of opinions with Group company compliance officers <p>Improve awareness of helpline</p> <ul style="list-style-type: none"> • Strengthen awareness among young people, dispatched staff, and part-time workers • Encourage companies with low recognition • Implement education for persons in charge of helpline contact points

Established Joint Review Meeting for Recurrence Prevention for inappropriate handling of wheeling information(announced on February 10, 2023)

Thorough compliance measures (announced on April 7, 2023)

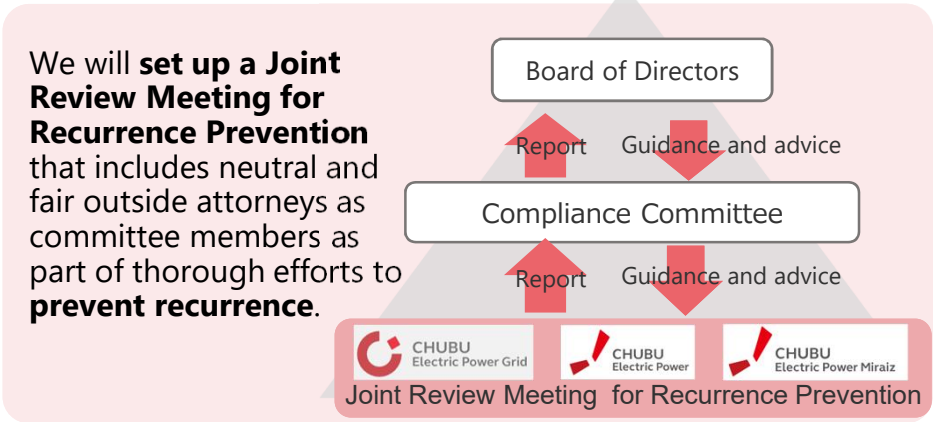

<p>1. Deepen awareness of compliance</p> <ul style="list-style-type: none"> • Compliance Awareness Improvement Program • Raise effectiveness of training and education • Implement behavioral checkpoints 	<p>3. Foster an even better organizational culture</p> <ul style="list-style-type: none"> • Create an open workplace • Prevent fading awareness
<p>2. Strengthen structures for compliance with antitrust laws</p> <ul style="list-style-type: none"> • Strengthen application of rules for contact with competitor companies • Strengthen internal reporting system • Strengthen checking functions 	<p>4. PDCA for thorough compliance measures</p> <ul style="list-style-type: none"> • Inspections by external experts • internal audits

